



Plans for EGNOS/SBAS in South Africa



ESESA 2nd Workshop 2,3 March 2011



EU South Africa Dialogue

- Started due to bilateral in February 2009
- Followed up in:
 - ✓ June 2009 Brussels
 - ✓ November 2009 Pretoria
 - ✓ July 2009 Brussels
 - ✓ November 2010
 - ✓ April 2011 Next Bilateral meeting between DST and DG Enterprise and Industry
- Themes:
 - ✓ Earth observation: GMES Africa
 - ✓ Space Science: Astronomy
 - ✓ Navigation: EGNOS Extension
- DST Responded to the letter from DG TREN to DG ENT.
- “South Africa’s commitment to cooperation with the EU in the field of satellite navigation, including with regard to EGNOS, was confirmed during the July 2010 meeting of the South Africa – EU Space Dialogue in Brussels. This commitment was reiterated during the recent meeting between South Africa’s Minister of Science and Technology, Ms Naledi Pandor, and Vice President Antonio Tajani of the European Commission, held in Beijing in November 2010”

- EGNOS RIMS
- FP6: AFSAGA
- EU South Africa Bilateral: EGNOS extension to Southern Africa
- FP7 ESES
- Galileo Hosting

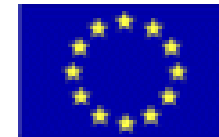

Application space

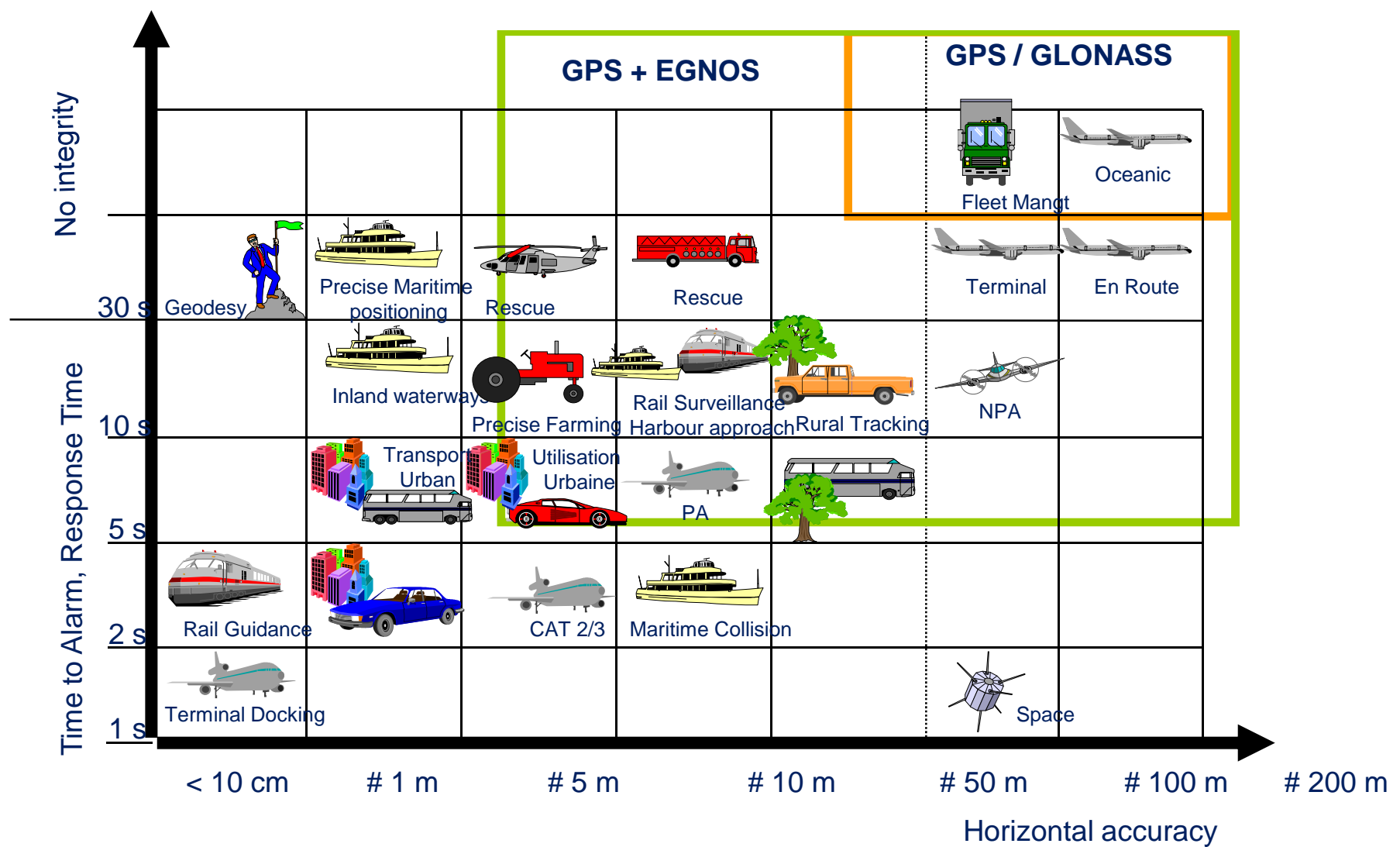

Navigation in Space Agency

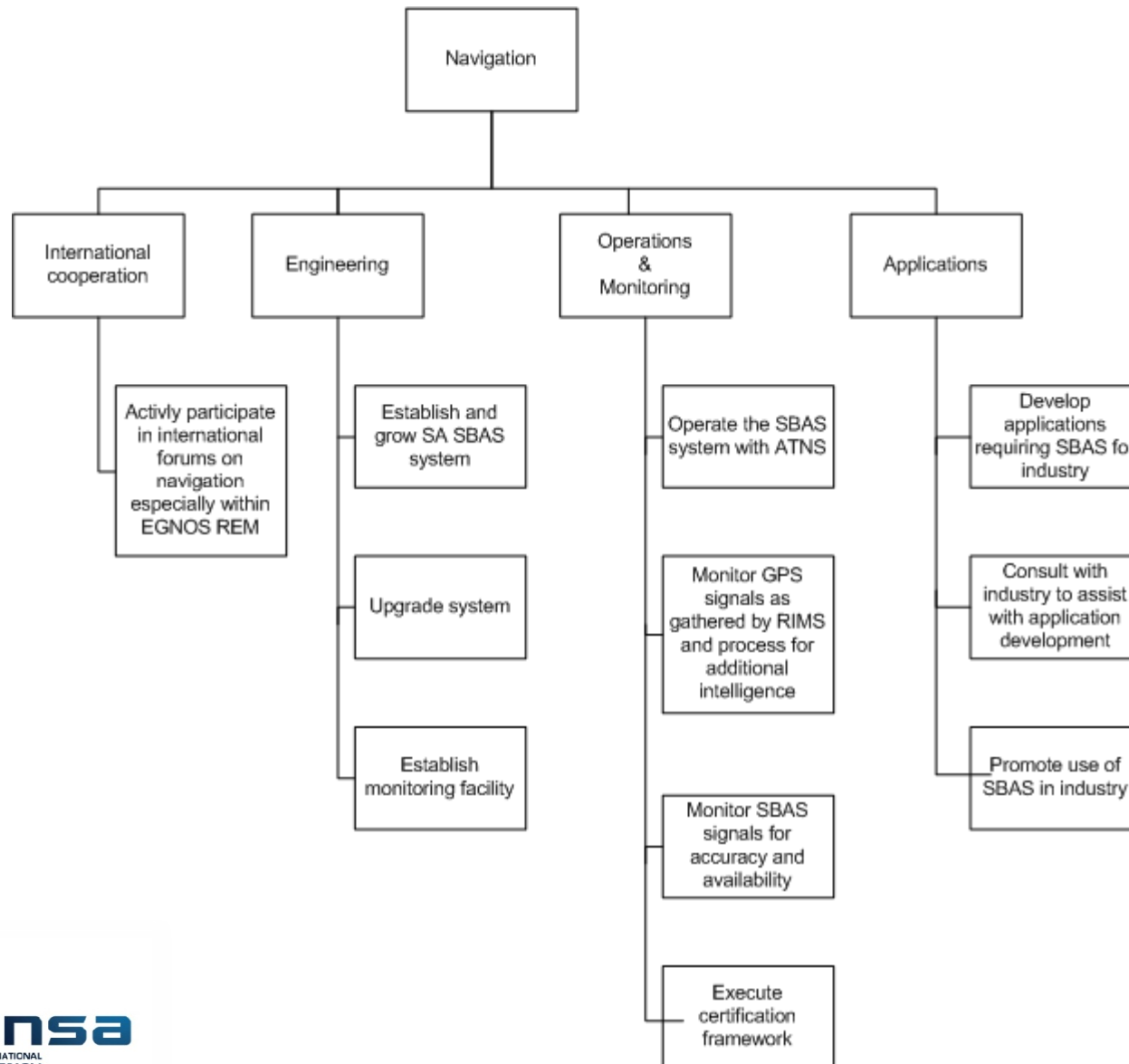

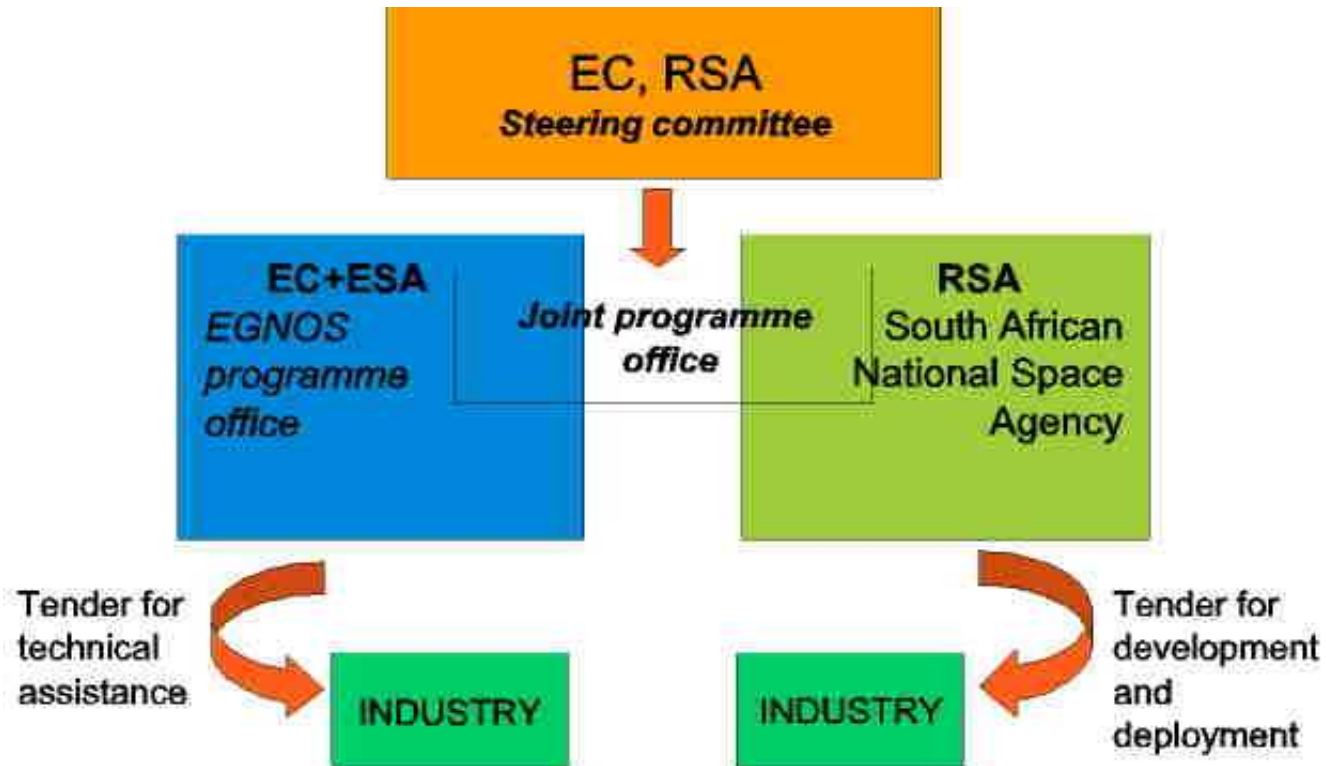

Picture 1 – Governance scheme for the project implementation

Structure for SBAS in South Africa

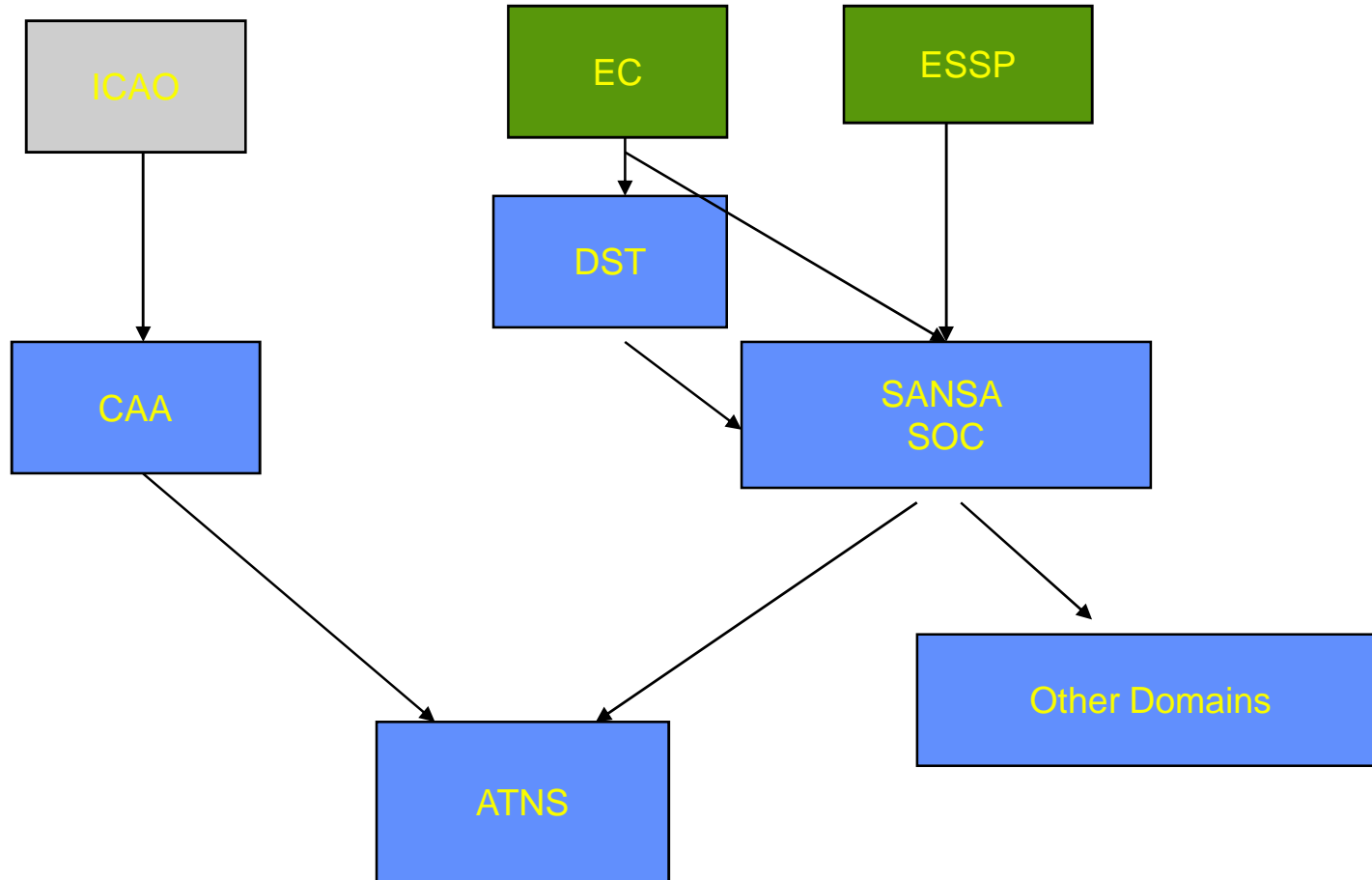

- ✓ **ISA: Interregional Satellite based augmentation system in Africa**
- ✓ **Reference stations installed in Africa (from 2002 to 2006)**
- ✓ **Provides corrections similar to those available in Europe**
- ✓ **Managed from Hönefoss, in Norway**

The EGNOS prototype success in Africa has proven technical feasibility of a fully operational system

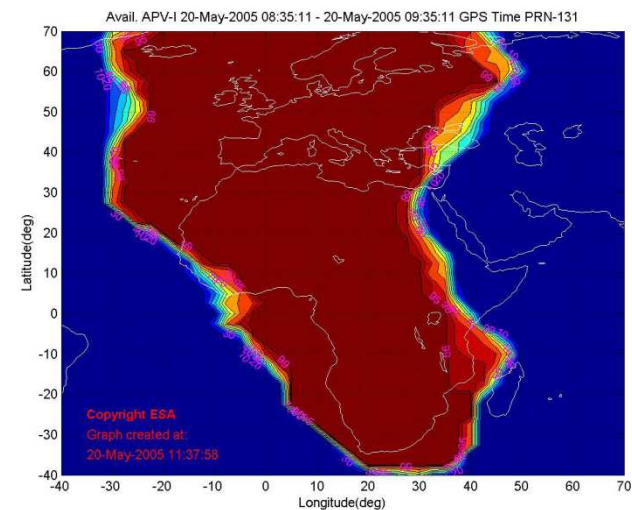

- Overwhelming 'business case'
- Sustained Funding
- Human Capital Development
- Clear responsibilities between South Africa and EU
- Achievable timelines
- Agreed technical performance

